

3570 Series Electric Mortice Lock



Designed and manufactured in Australia, the 3570 series electric mortice is a high performance lock of superior quality. It is constructed from high grade zinc alloy, with a stainless steel latch bolt and face plate and is suited for all commercial applications.

The lock can be operated by push buttons, intercom systems and key switches; or integrated with electronic access control systems for use with higher security devices such as keypads or card readers.

Standards and Compliance

S8

(Security) Australian Lock Standard (AS4145.2.2008) (when used with equivalent security level keying system)

D8

(Durability) Australian Lock Standard (AS4145.2.2008)



Successfully fire rated up to 4hrs on fire door assemblies in accordance with AS1905.1. 2005 (Part 1: Fire resistant door sets)



C-Tick Certified

Product Details

Voltage	12VDC - 24VDC Operating Voltage
Current	500mA (max) 80mA holding @ 12VDC 275mA (max) 50mA holding @ 24VDC
LED Current	When LED's are fitted, add 15mA (max) to total current draw
Monitoring	Dual Key override Deadlatched Locked Door closed Request to exit Microswitches: 500mA (max) @ 30VDC each circuit Reedswitch: 100mA (max) @ 30VDC
Environment	Operational temperature range -20c to +60c
Case/Cover	High purity Zinc alloy construction
Backset	60mm standard, 89 & 127 mm available
Latch Bolts	Reversible with Stainless Steel construction
Door Clearance	3 - 6.5 mm
Door Thickness	Standard applications 32 to 50mm
Cylinder	Standard Lockwood oval shaped cylinders
Cabling	1.6 metre length of cable with 12 pin socket supplied with each lock. Recommended cable: 18AWG (0.82mm ²) cable runs up to 30m
Furniture	Compatible with Lockwood series door furniture
Standard Finishes	Satin Chrome (SC) standard.

3570 Series Electric Mortice Lock

Key Features

Designed with flexibility in mind, the one lock can cover all functions and is easily configured on site for the required application.

Available in non monitored and monitored versions.

Monitoring Features:

- Dead latched and Locked
- Door position/Reed switch
- Dual key override monitoring
- Request to exit/REX
- LED indication

Field Changeable Settings:

- Fail safe/fail secure configuration.
- Multi-voltage - will work on 12-24 VDC systems.
- Handing - left hand and right hand doors
- Selection of free lever or locked lever on both sides of the door
- Key override monitoring either side of the door
- Monitoring contacts – normally closed, normally open (for key override and request to exit only)

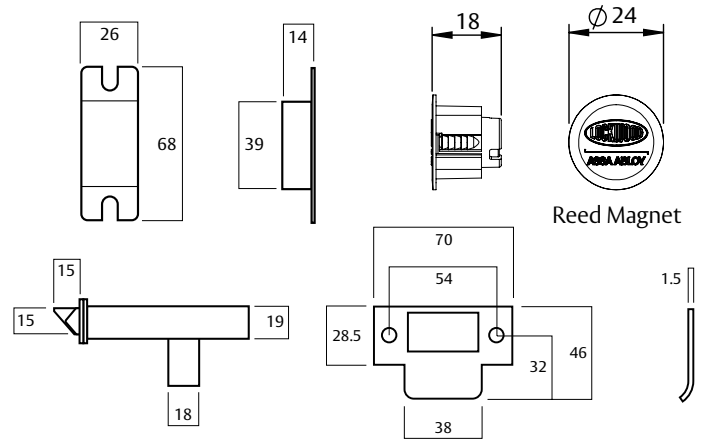
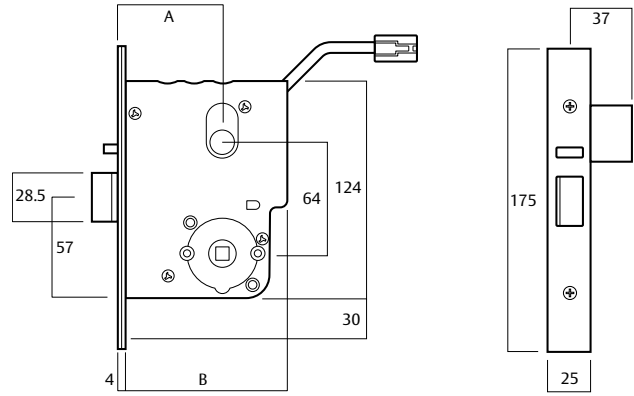

3570 Series Electric Mortice Lock

Dimension	Backset		
A	60	89	127
B	100	129	167

Specification Statement

The lock should be capable of operation on voltages between 12 – 24VDC and have a current consumption not more than 80mA (holding) @12VDC and 50mA (holding) @24VDC. Monitored locks must be capable of monitoring the following functions: Key override, door position / reed switch, selectable hub / Request to exit, & locking bar status. All monitoring outputs must have the ability to be wired independently. All settings – including: fail safe / fail secure, handing, hub selection must be field configurable.

3570 Series Electric Mortice Lock

Ordering Procedure

Sample part number 3572ELAM2RSC is made up of several sections. Choose your product by selecting an option from each section.

Backset	Fixing	Lock Functions	Electric Lock	Safety Function	Sub Function	Handing	Finish
3	5	72	EL	A	M2	R	SC
Backset	Lock Function	Safety Function	Handing				
60 mm	3	Primary Lock	70	Fail Safe (Power to lock)	A	Right Handed	R
89 mm	4	Vestibule Lock	72	Fail Secure (Power to unlock)	E	Left Handed	L
127 mm	5	Combination Lock	74				
Fixing	Electric Lock	Sub Function	Finish				
Standard	5	Electric Lock	EL				
				Sub Function			
				Non-monitored Lock (0 Cylinders)	N0		
				Non-monitored Lock (1 Cylinders)	N1		
				Non-monitored Lock (1 Cylinder)	N1		
				Non-monitored Lock (2 Cylinders)	N2		
				Fully monitored Lock including KOM (0 Cylinders)	M0		
				Fully monitored Lock including KOM (1 Cylinder)	M1		
				Fully monitored Lock including KOM (2 Cylinders)	M2		

Ordering Notes

- 3570 primary locks can be set to achieve all lock functions post purchase, and should be the preferred option when ordering.
- Customised locks are available upon request and incur an additional surcharge and 10 day lead time.
- See over page for primary lock part numbers.

Handing Chart

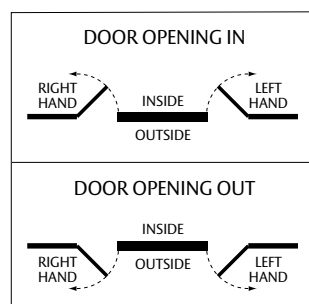

Backset Nominate backset as required, e.g. 60mm	3
Fixing Select the desired fixing method, e.g. Standard Fixing 35	35
Lock Function Select function, e.g. Vestibule Lock	3572
Electrical Variant Indicate that this is an Electric Lock	3582EL
Safety Function Select whether lock should be Fail Secure or Fail Safe, e.g. Fail Safe	3572ELA
Monitoring and Key Override Options Select monitoring and cylinders to be supplied, e.g. Monitored Lock with two cylinders	3572ELAM2
Handing Determine left or right handing, e.g. Right Handed	3572ELAM2R
Finish Specify appropriate finish, e.g. Satin Chrome	3572ELAM2RSC

3570 Series Electric Mortice Lock

Primary Electric Mortice Lock Ordering Procedure

Part Number	Cylinders	Product Description - Non-Monitored
3570ELN0SC	No Cylinder	Electric Mortice Lock 3570 Primary Lock 60 mm Backset Non Monitored
3570ELN1SC	1 Cylinder	Electric Mortice Lock 3570 Primary Lock 60 mm Backset Non Monitored
3570ELN2SC	2 Cylinders	Electric Mortice Lock 3570 Primary Lock 60 mm Backset Non Monitored
4570ELN0SC	No Cylinder	Electric Mortice Lock 4570 Primary Lock 89mm Backset Non Monitored
4570ELN1SC	1 Cylinder	Electric Mortice Lock 4570 Primary Lock 89 mm Backset Non Monitored
4570ELN2SC	2 Cylinders	Electric Mortice Lock 4570 Primary Lock 89 mm Backset Non Monitored
5570ELN0SC	No Cylinder	Electric Mortice Lock 5570 Primary Lock 127 mm Backset Non Monitored
5570ELN1SC	1 Cylinder	Electric Mortice Lock 5570 Primary Lock 127 mm Backset Non Monitored
5570ELN2SC	2 Cylinders	Electric Mortice Lock 5570 Primary Lock 127 mm Backset Non Monitored
Part Number	Cylinders	Product Description - Monitored (hub, deadlatch, solenoid, door position, key override monitoring all as standard)
3570ELM0SC	No Cylinder	Electric Mortice Lock 3570 Primary Lock 60 mm Backset Monitored
3570ELM1SC	1 Cylinder	Electric Mortice Lock 3570 Primary Lock 60 mm Backset Monitored
3570ELM2SC	2 Cylinders	Electric Mortice Lock 3570 Primary Lock 60 mm Backset Monitored
4570ELM0SC	No Cylinder	Electric Mortice Lock 4570 Primary Lock 89 mm Backset Monitored
4570ELM1SC	1 Cylinder	Electric Mortice Lock 4570 Primary Lock 89 mm Backset Monitored
4570ELM2SC	2 Cylinders	Electric Mortice Lock 4570 Primary Lock 89 mm Backset Monitored
5570ELM0SC	No Cylinder	Electric Mortice Lock 5570 Primary Lock 127 mm Backset Monitored
5570ELM1SC	1 Cylinder	Electric Mortice Lock 5570 Primary Lock 127 mm Backset Monitored
5570ELM2SC	2 Cylinders	Electric Mortice Lock 5570 Primary Lock 127 mm Backset Monitored

Ordering Notes

- Primary locks can be set post purchase to achieve all desired lock settings e.g. fail safe or fail secure, left hand or right hand, combination lock (locked both sides) or vestibule lock (locked outside and free lever inside)
- All locks are multi-voltage 12-24VDC
- 3570 primary locks (std 60mm backset) with no cylinder are stocked items. All other items are made to order, 10 day lead time.

3570 Series Electric Mortice Lock

Accessories - Rebate Kits

Part Numbers	"A"	Finish
3772-RK32CP 3772-RK46CP	32 46	Chrome Plate
3772-RK32PB 3772-RK46PB	32 46	Polished Brass
3772-RK32SS 3772-RK46SS	32 46	Satin Stainless Steel

Accessories - Long Lipped Strikes

Part Numbers	"A"	Finish
3772-STK43CP 3772-STK47CP	43.5 47.5	Chrome Plate
3772-STK43PB 3772-STK47PB	43.5 47.5	Polished Brass
3772-STK43SS 3772-STK47SS	43.5 47.5	Satin Stainless Steel

Accessories - Cable Accessories

Part Numbers	Finish
SP572-3129	LED assembly to suit 3570/3580 (suits furniture for monitored locks)
SP3570-1055	Extended 7.5M cable (12 wire) to suit 3570 locks
SP3570-5871	9/12 wire adaptor
LC8810	323mm Power Transfer Cable
LC8811	543mm Power Transfer Cable

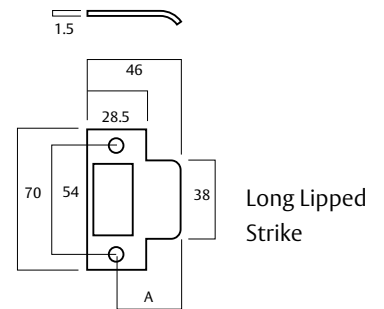
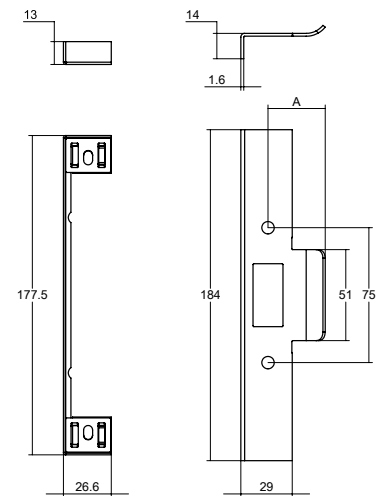

3570 Series Electric Mortice Lock

Electrical Specifications

Circuit Diagram

Note: Diagram depicts fail safe RH opened door, with handle and key in rest state.

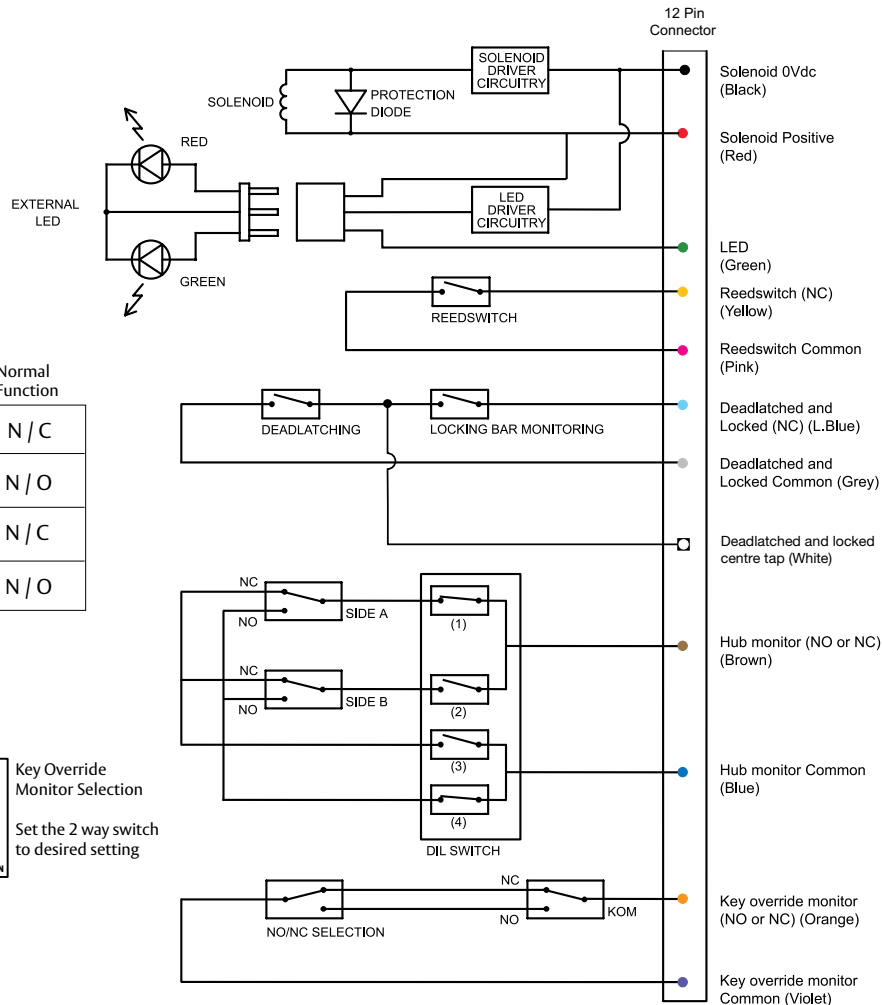

DIL Switch Settings

Hub Monitor

	Switch Number	Lock Side	Normal Function			
	1	2	3	4		
ON	■	■	■	■	A	N / C
OFF	□	□	□	□	A	N / O
ON	■	■	■	■	B	N / C
OFF	□	□	□	□	B	N / O

Key Override Monitor Selection

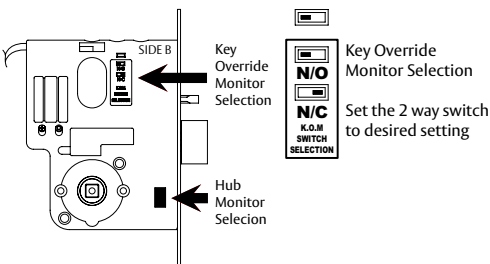

Solenoid Activation

Operating Voltage:

12 - 24VDC

Operating Current:

500mA (max) 80mA holding @ 12VDC

275mA (max) 50mA holding @ 24VDC

For confirmation of the above mentioned operating current, please see installation manual

LED Current

Where LEDs are fitted, add 20mA (max) to total operating current

Monitoring Circuits

Microswitches: 500mA (max) @ 30VDC each circuit

Reedswitch: 100mA (max) @ 30VDC

Colour

Function

Black	Solenoid (0VDC)
Red	Solenoid Positive (12VDC - 30VDC)
Green	LED (12VDC - 30VDC)
Yellow	Door Closed Reedswitch (NC)
Pink	Door Closed Reedswitch (Common)
Light Blue	Deadlatched and Locked (NC)
Grey	Deadlatched and Locked (Common)
White	Deadlatched and Locked Centre Tap
Brown	Hub Monitor (NO or NC)
Blue	Hub Monitor (Common)
Orange	Key Override Monitor (NO or NC)
Violet	Key Override Monitor (Common)

3579 Series Electric Mortice Lock





Designed and manufactured in Australia, the 3579 series electric mortice is a high performance lock of superior quality. It is constructed from high grade zinc alloy secured between stainless plates making suitable for high security applications.

The 3579 lock can be operated by push buttons, intercom systems and key switches; or integrated with electronic access control systems for use with higher security devices such as keypads or card readers.

Product Details

Voltage	12VDC - 24VDC Operating Voltage
Current	500mA (max) 80mA holding @ 12VDC 275mA (max) 50mA holding @ 24VDC
LED Current	When LED's are fitted, add 15mA (max) to total current draw
Monitoring	Dual Key override Deadlatched Locked Door closed Request to exit Microswitches: 500mA (max) @ 30VDC each circuit Reedswitch: 100mA (max) @ 30VDC
Environment	Operational temperature range -20c to +60c
Case/Cover	High purity Zinc alloy construction with Stainless Steel plates
Backset	60mm standard, 89 & 127mm available
Latch Bolts	Reversible with Stainless Steel construction
Door Clearance	3 - 6.5mm
Door Thickness	Standard applications 32 to 50mm
Cylinder	Standard Lockwood oval shaped cylinders
Cabling	1.6 metre length of cable with 12 pin socket supplied with each lock. Recommended cable: 18AWG (0.82mm ²) cable runs up to 30m
Furniture	Compatible with Lockwood series door furniture
Standard Finishes	Satin Chrome (SC) standard

Standards and Compliance

SL8	Australian Lock Standard (AS4145.2.2008) (when used with equivalent security level keying system)
D8	(Durability) Australian Lock Standard (AS4145.2.2008)
	Successfully fire rated up to 4hrs on fire door assemblies in accordance with AS1905.1. 2005 (Part 1: Fire resistant door sets)
	C-Tick Certified
	SCEC endorsed for secure areas

3579 Series Electric Mortice Lock

Key Features

Designed with flexibility in mind, the one lock can cover all functions and is easily configured on site for the required application.

- Stainless Steel Latch and Faceplate
- Stainless steel plates that encapsulate the body against attempted vandalism
- Available in Monitored versions only

Monitoring Features

- Dead latched and Locked
- Door position/Reed switch
- Dual key override monitoring
- Request to exit/REX
- LED indication

Field Changeable Settings

- Fail safe/fail secure configuration.
- Multi-voltage - will work on 12-24 VDC systems.
- Handing - left hand and right hand doors
- Selection of free lever or locked lever on both sides of the door
- Key override monitoring either side of the door
- Monitoring contacts – normally closed, normally open (for key override and request to exit only)

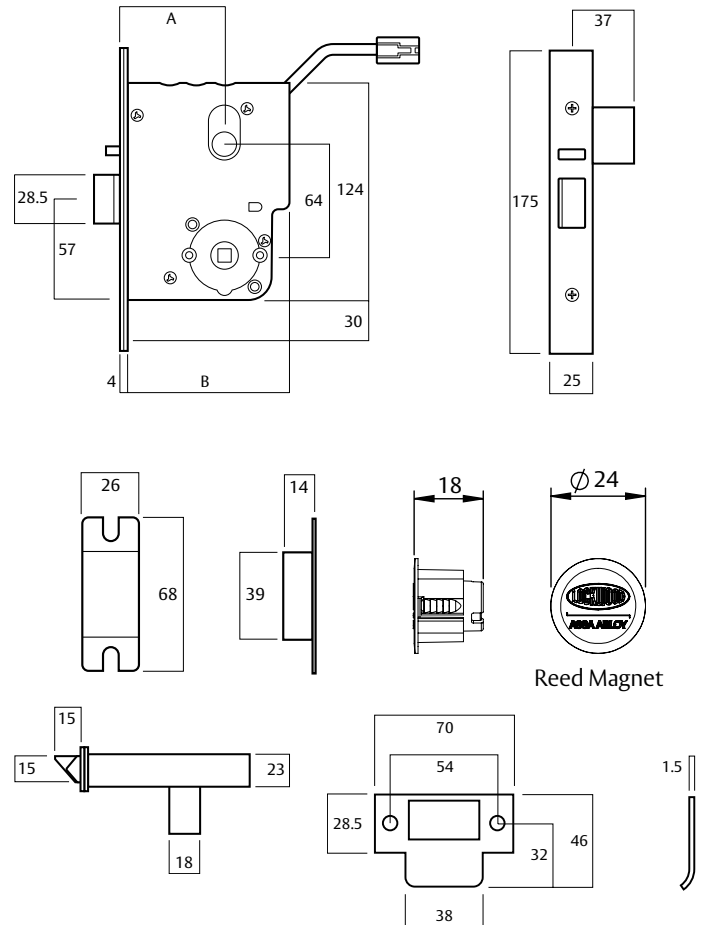

3579 Series Electric Mortice Lock Ordering Procedure

Part Number	Product Description
3579ELM0SC	Electric Mortice Lock 3579 Primary Lock 60 mm Mon
4579ELM0SC	Electric Mortice Lock 3570 Primary Lock 89 mm Mon
5579ELM0SC	Electric Mortice Lock 3570 Primary Lock 127 mm Mon

Specification Statement

The lock body should be encapsulated with stainless steel. The lock should be capable of operation on voltages between 12 – 24VDC and have a current consumption not more than 80mA (holding) @12VDC and 50mA (holding) @24VDC. Monitored locks must be capable of monitoring the following functions: Key override, door position / reed switch, selectable hub / Request to exit, & locking bar status. All monitoring outputs must have the ability to be wired independently. All settings – including: fail safe / fail secure, handing, hub selection must be field configurable.

3579HS Series Electric Mortice Lock





Designed and manufactured in Australia, the 3579HS series electric mortice is designed for unique applications where fail secure functionality is required externally with fail safe functionality on the inside. To achieve this function the lock must be used in conjunction with an electric strike.

The 3579HS is constructed from the same material as the 3579 counterpart.

Product Details

Voltage	12VDC - 24VDC Operating Voltage
Current	500mA (max) 80mA holding @ 12VDC 275mA (max) 50mA holding @ 24VDC
LED Current	When LED's are fitted, add 15mA (max) to total current draw
Monitoring	Dual Key override Deadlatched Locked Door closed Request to exit Microswitches: 500mA (max) @ 30VDC each circuit Reedswitch: 100mA (max) @ 30VDC
Environment	Operational temperature range -20c to +60c
Case/Cover	High purity Zinc alloy construction with Stainless Steel plates
Backset	60mm standard, 89 & 127mm available
Latch Bolts	Reversible with Stainless Steel construction
Door Clearance	3 - 6.5mm
Door Thickness	Standard applications 32 to 50mm
Cylinder	Standard Lockwood oval shaped cylinders
Cabling	1.6 metre length of cable with 12 pin socket supplied with each lock. Recommended cable: 18AWG (0.82mm ²) cable runs up to 30m
Furniture	Compatible with Lockwood series door furniture
Standard Finishes	Satin Chrome (SC) standard

Standards and Compliance

SL8	Australian Lock Standard (AS4145.2.2008) (when used with equivalent security level keying system)
D8	(Durability) Australian Lock Standard (AS4145.2.2008)
	Successfully fire rated up to 4hrs on fire door assemblies in accordance with AS1905.1. 2005 (Part 1: Fire resistant door sets)
	C-Tick Certified
	SCEC endorsed for secure areas

3579HS Series Electric Mortice Lock

Key Features

Designed with flexibility in mind, the one lock can cover all functions and is easily configured on site for the required application.

- Stainless Steel Latch and Faceplate
- Stainless steel plates that encapsulate the body against attempted vandalism
- Available in Monitored versions only

Monitoring Features

- Dead latched and Locked
- Door position/Reed switch
- Dual key override monitoring
- Request to exit/REX
- LED indication

Field Changeable Settings

- Fail safe/fail secure configuration.
- Multi-voltage - will work on 12-24 VDC systems
- Handing - left hand and right hand doors
- Selection of free lever or locked lever on both sides of the door
- Key override monitoring either side of the door
- Monitoring contacts – normally closed, normally closed

Note: this lock is designed to operate in conjunction with an electric strike. The lock will never unlock electrically from the external side.

Lock Functions

The 3579HS series lock is designed to provide internal emergency egress on doors whereby the door remains secure on the outside in the event of a fire alarm or break glass event.

A typical door set up would include the following hardware:

- Proximity readers on both sides of the door to gain access either way
- 3579HS Electric Mortice Lock set to fail safe inside. Note the lock remains in the locked state (externally) 100% of the time if power is applied or not.
- Electric strike set to fail secure
- Break glass or Fire Panel connected to the mortice lock only

To enter or exit the door the user would swipe a proximity card to the reader. Upon authorisation from the EAC panel the electric strike would unlock, allowing the user to open the door. The electric mortice lock does not change state.

In the event of an emergency (fire alarm or break glass activation), power is cut to the electric mortice lock & places it in a fail safe mode on the internal side only. The mortice lock remains in a fail secure state on the external side.

Note: The 3579HS Series lock can never be electrically unlocked from the outside. A secondary locking device (electric strike) must be used in conjunction with this lock.

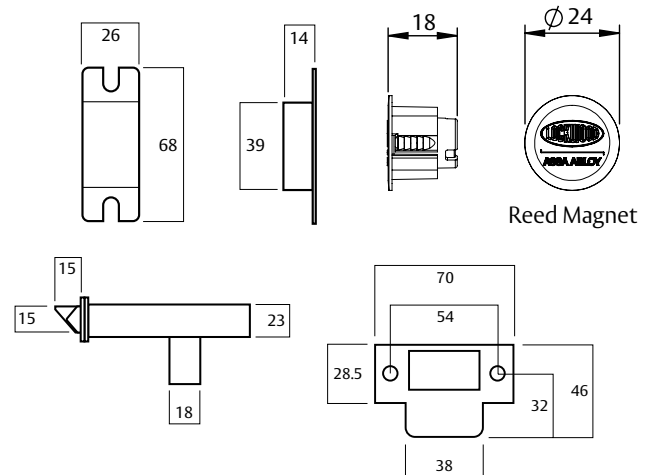
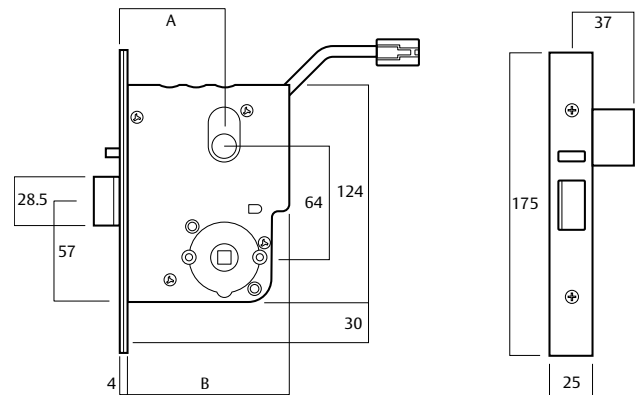

3579 Series Electric Mortice Lock Ordering Procedure

Part Number	Product Description
3579HSELM0SC	High Security Elec Mortice 3579HS Primary Lock 60 mm
4579HSELM0SC	High Security Elec Mortice 3579HS Primary Lock 89 mm
5579HSELM0SC	High Security Elec Mortice 3579HS Primary Lock 127 mm

Specification Statement

The lock body should be encapsulated with stainless steel. The lock should be capable of operation on voltages between 12 – 24VDC and have a current consumption not more than 80mA (holding) @12VDC and 50mA (holding) @24VDC. Monitored locks must be capable of monitoring the following functions: Key override, door position / reed switch, selectable hub / Request to exit, & locking bar status. All monitoring outputs must have the ability to be wired independently. All settings – including: fail safe / fail secure, handing, hub selection must be field configurable. The lock must be capable of operating in fail safe mode internally and fail secure mode externally when used in conjunction with an electric strike.